



METHANE
GUIDING
PRINCIPLES

Reducing Methane Emissions: Best Practice Guide Flaring

November 2019



Disclaimer

This document has been developed by the Methane Guiding Principles partnership. The Guide provides a summary of current known mitigations, costs, and available technologies as at the date of publication, but these may change or improve over time. The information included is accurate to the best of the authors' knowledge, but does not necessarily reflect the views or positions of all Signatories to or Supporting Organisations of the Methane Guiding Principles partnership, and readers will need to make their own evaluation of the information provided. No warranty is given to readers concerning the completeness or accuracy of the information included in this Guide by SLR International Corporation and its contractors, the Methane Guiding Principles partnership or its Signatories or Supporting Organisations.

This Guide describes actions that an organisation can take to help manage methane emissions. Any actions or recommendations are not mandatory; they are simply one effective way to help manage methane emissions. Other approaches might be as effective, or more effective in a particular situation. What readers choose to do will often depend on the circumstances, the specific risks under management and the applicable legal regime.

Contents

- Summary..... 2
- Introduction..... 3
- Quantifying emissions 4
- Mitigation strategies..... 5
- Checklist..... 14
- Appendix..... 15
- References..... 16

Summary



Flares are emission-control devices used to burn flammable gases which would otherwise be released into the atmosphere. In petroleum and natural-gas supply chains around the world, it is estimated that open flaring burns approximately 145 billion cubic meters of gas per year.

The amount of methane emissions from this flaring is estimated to be approximately 2 million metric tons, or 2% of the estimated methane emissions from global oil and gas production.¹

There are multiple ways to reduce emissions from flaring. Ideally, waste gas production is prevented. If this is not feasible then waste gas recovery for sale can generate revenue. Otherwise, storing (re-injecting) gases in oil and gas reservoirs is also an alternative. If the waste gas cannot be recovered to be sold as a natural gas or natural-gas liquid product, or cannot be stored, it may be able to be used for generating electricity. If flaring cannot be prevented, improving the efficiency of flares can reduce emissions of methane.

Best practice strategies for reducing methane emissions from flaring:

- ✓ Keep an accurate inventory of flaring activities
- ✓ Prevent flaring by designing systems that do not vent gases
- ✓ Recover gases that are currently being flared, so they can be sold as natural gas or natural-gas liquid products
- ✓ Store gases (through injecting into gas or oil reservoirs) that cannot be recovered and immediately sold
- ✓ For gases that cannot be sold as natural gas or natural-gas liquid, find alternative uses such as generating electricity
- ✓ For gases that need to be flared, make sure the combustion of those gases is efficient
- ✓ Track flaring and venting activities in an annual inventory

Introduction

Flaring may arise for safety reasons, because more gas than can be used is produced, or as routine emission control.

- **Flaring may be needed for safety reasons** at wells and gas-processing facilities during activities such as well-completion (making a well ready for production), routine and non-routine maintenance, and emergency shutdowns.
- **Flaring may be needed because more gas than can be used is produced.** This may be for a number of reasons, including lack of infrastructure for gathering gases, over-supplies and pressure imbalances, equipment being temporarily shut down, and natural-gas liquid pooling. If gas is produced from oil wells before gas-gathering lines are available, flaring may be used. Even if there is infrastructure for gathering gases, the initial, high-pressure, high-flow production from new wells can overwhelm gathering systems and the excess gas may be flared. Condensate forming in gathering lines can also lead to flaring.
- **Flaring may be used as a routine emission control,** to control some types of emissions that might otherwise be vented and released into the atmosphere.

The scale of flaring is routinely quantified based on satellite measurements of light intensity. These emissions do not include flaring in enclosed spaces, but nevertheless, give an indication of the scale and distribution of flaring at any one time.

In 2018, the World Bank's Global Gas Flaring Reduction Partnership (World Bank, 2019) reported that open flaring burned approximately 145 billion cubic meters (bcm) of gas per year.¹ This was almost 4% of the 3,870 bcm of natural gas produced worldwide in 2018. The distribution of this flaring is shown in figure 1 below. If the 145 bcm of gas that was flared could have been sold, it would be worth

US\$15 billion to US\$20 billion per year (based on the value of the gas ranging from US\$3 to US\$4 per thousand standard cubic feet (US\$0.11 to US\$0.14 per standard cubic meter).

Figure 1: Flared gas volumes by country (top 10 countries and the rest of the world), quantified based

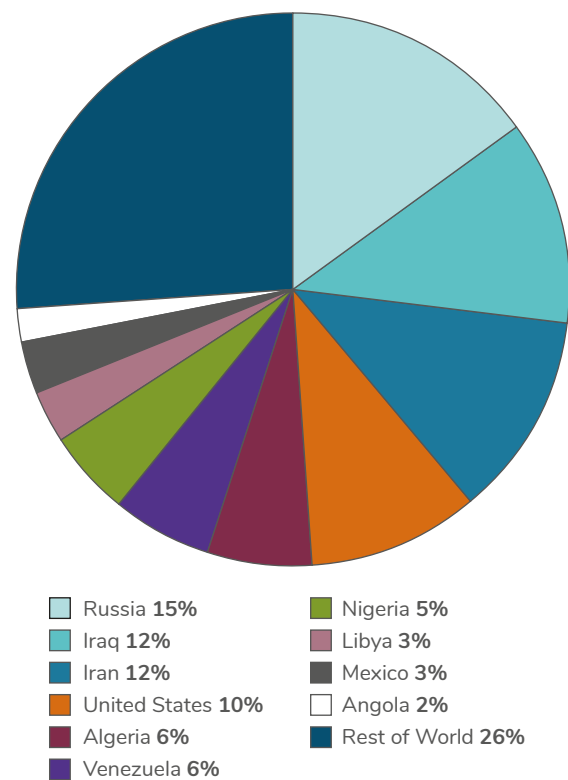

Source: Reference 1

Quantifying emissions

Flaring of gas results in significant methane emissions. It is generally assumed that flares operate at 98% efficiency, meaning that 2% of the waste gas is not burned, and approximately 2 million metric tons per year of methane is released into the atmosphere as unburned gas.

In most countries with large-scale flaring activity (for example, Russia, Iraq, Iran), flaring is associated with conventional oil and gas production. However, in the United States, flaring is mainly associated with unconventional oil and gas production.²

Flow rates of flared gas can vary widely between locations. Analysis of information from the United States and Canada indicate that a small fraction of sites tend to account for the majority of the flared gas.^{3,4} In Alberta, approximately 10% of sites accounted for half the gas flared,³ whereas in the United States, less than 5% of 20,000 flares accounted for half of the total volume of gas flared.⁴ This means that mitigation strategies may only be economical for a small number of sites where flares operate at high flow rates, and which account for a large fraction of flared gas.

Flow rates of flared gas can also vary over time, particularly for unconventional oil production (where production declines rapidly), or in regions where the infrastructure for using gas is being constructed. The duration of flaring may also influence how economically viable certain mitigation strategies are.

Mitigation strategies

Best practice for reducing flaring includes preventing waste gas from being generated, recovering waste gas to sell it and injecting waste gas into oil and gas reservoirs.

If waste gas cannot be recovered to be sold or injected into gas or oil reservoirs, it may be able to be used for generating electricity. As a final option, when flaring cannot be avoided, improving the efficiency of flaring can reduce methane emissions.

Flaring and mitigation strategies are summarized in table 1 below. Other mitigation strategies that prevent venting of gases (for example, preventing condensation from natural gas from pooling in process lines) may also reduce flaring. Further mitigation measures are described in other best-practice guides.

The remainder of this document describes the mitigation strategies listed in table 1 below. Links to more information are provided in the Appendix.

Table 1: Methods for reducing flaring

Mitigation strategy	Description
1. Prevent the need for flaring	Add a second separator when designing wells
2. Recover flared gases and sell them as natural gas or natural-gas liquid	2a Add vapor-recovery units on tanks
	2b Reduce flaring during well-testing and completion
	2c Compress natural gas and transport it by road
	2d Recover natural-gas liquids
3. Store gases that would otherwise be flared	Store gases by injecting them into oil or gas reservoirs
4. Find alternative uses for flared gases	Use waste gases to generate electricity
5. Improve the efficiency of flaring	5a Improve combustion in manned steam- or air-assisted flares
	5b Improve combustion in small flares at unmanned sites

Mitigation strategy 1: Add a second separator when designing wells⁵

Upstream production sites that produce condensate or crude oil send hydrocarbon liquid from a pressurized separator to a non-pressurized condensate tank. Methane will ‘flash’ from the liquid in the tank and may be flared. Flaring of this ‘flash gas’ can be significantly reduced by installing a second separator on the site.

Oil, water and gas are separated by sending the fluids to a separator, which operates at a pressure intermediate between the pressure at the wellhead and the atmospheric pressure in the condensate tank. If two-stage separation is introduced, as shown in figure 2 below, production of hydrocarbon liquids can be increased and venting reduced.

Two-stage separation is only possible with a high-pressure well, and compression may be needed for the low-pressure gas produced by the second stage of separation. The Reid vapor pressure (RVP) of the condensate or crude oil produced through two-stage separation will increase compared with the amount produced through single-stage separation, but can still be below regulated values in many jurisdictions.

Reduction in emissions and recovering costs

Two-stage separation has been evaluated in the Eagle Ford production region in south central Texas.⁵ With a second separator, overall production of hydrocarbon gas increased by approximately 15 to 20%, production of hydrocarbon liquid increased by approximately 1 to 4%, and vent gases decreased by approximately 65 to 75%. Estimated costs for installing two-stage separation were roughly three times

Figure 2: Adding a second stage of separation increases production of hydrocarbon liquid and hydrocarbon gas while reducing the amount of vent gas to be flared

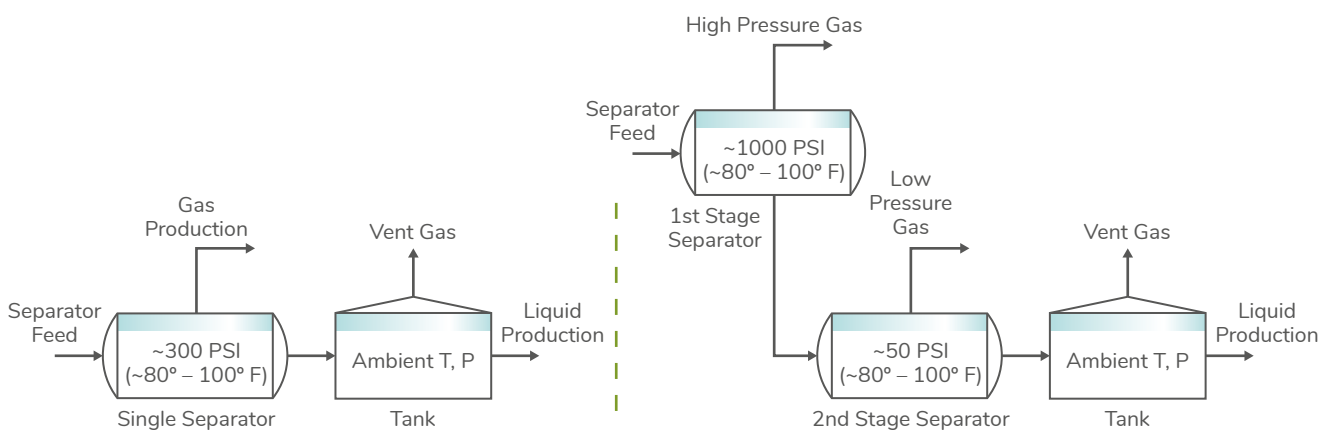

more than installing single-stage separation. While specific payback times (how long it takes to recover the extra costs) are not reported, the increased production associated with adding a second separator suggests a payback time of several months.⁵

Mitigation strategy 2a: Add vapor-recovery units on tanks⁶

Upstream production sites that produce condensate or crude oil send hydrocarbon liquid from a pressurized separator to a non-pressurized condensate tank. Methane will ‘flash’ from the liquid in the tank and may be vented or flared. This flash of methane is also possible in tanks that hold water (though to a far lower degree because methane is highly soluble in liquid hydrocarbon but not very soluble in water).

Vapor-recovery systems can capture the flash gas, compress it and transport it through a gas line to be sold, rather than it being vented to the atmosphere or it being flared. A vapor-recovery system could be as simple as a small compressor designed to operate when the pressure in the tank reaches a certain level, or it could be an upstream vapor-recovery tower (VRT) that acts as a separator for flash gas and allows the vapor-recovery unit’s compressor to work in more stable modes.

A vapor-recovery system may also include a flare if it is not designed to recover the potential maximum gas flow from the site. The flare then acts when excess flash gas comes from the tanks, and so prevents venting.

Any production site that produces flash gas can reduce emissions by adding a vapor-recovery system. Some sites (such as in Canada and the US)

Figure 3: Vapor-recovery units can divert flash gases so they can be sold

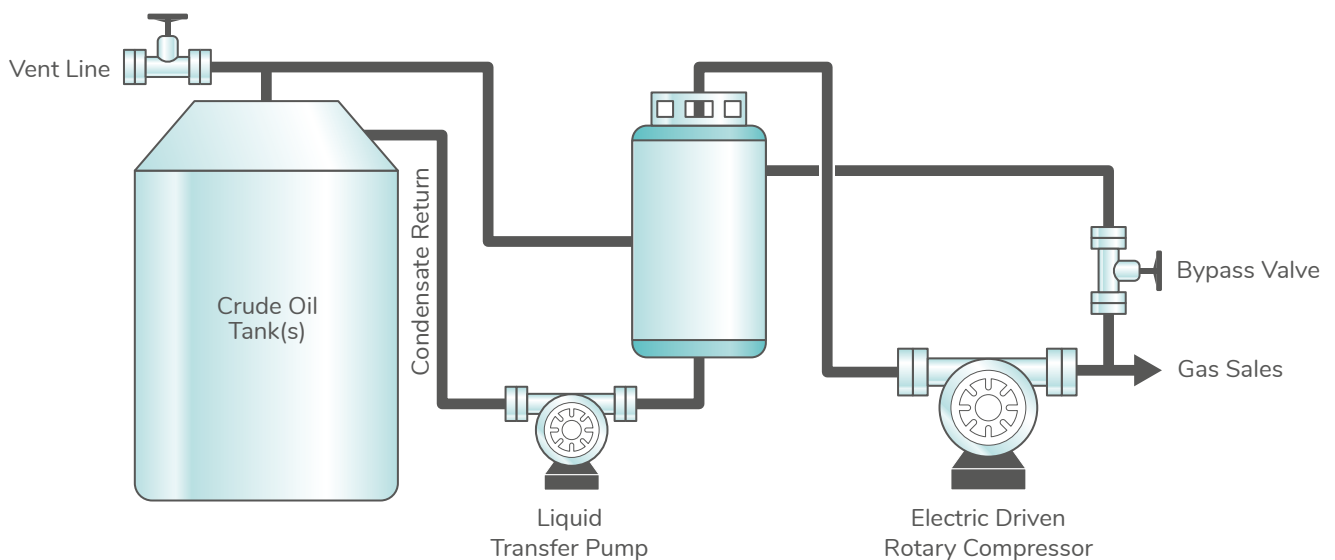

Mitigation strategies

must have these by regulation for tanks that release more than a set volume of gas. Elsewhere, vapor-recovery systems may be added for economic benefit, if the recovered gas is worth more than the cost of adding vapor recovery, or because of a voluntary corporate policy.

Reduction in emissions and recovering costs

Vapor-recovery systems can be designed to recover more than 90% of gas that might otherwise be vented or flared.⁶ However, as recovering vapor almost always requires compression and other equipment, the value of the recovered vapor that can then be sold must be compared against the initial and operating costs of all parts of a vapor-recovery system.

Mitigation strategy 2b: Reduce flaring during well-testing and completion⁷

After drilling new wells, the well is brought into production using a process called completion. During completion, drill cuttings, sand and

fracturing fluid (fluids from fracking) are recovered before the well is connected to the gas lines. This process can result in venting or flaring of the gas that flows back during completion. Reducing the volume of flowback gas can reduce the amount flared or vented. Many jurisdictions such as the US and Canada now require a 'green completion' or 'reduced emission completion' where separators are used during completion to capture the gas that would otherwise be vented. If the captured gas from the separator is sold, emissions and flaring are reduced. If the captured gas is flared, emissions are still reduced compared to venting (see the guide on reducing emissions from venting for more details).

During well-testing, gas is released to test flow rates, which may result in venting or flaring. Temporary equipment is used to capture the released gas. Quite often, a separator for gas from well-testing is much larger than the permanent separator for the well, so it may be brought on a site only for the period of the well-testing.

Figure 4: Reduced emission completions can reduce gas venting and, if the captured gases can be sold, can also reduce flaring.

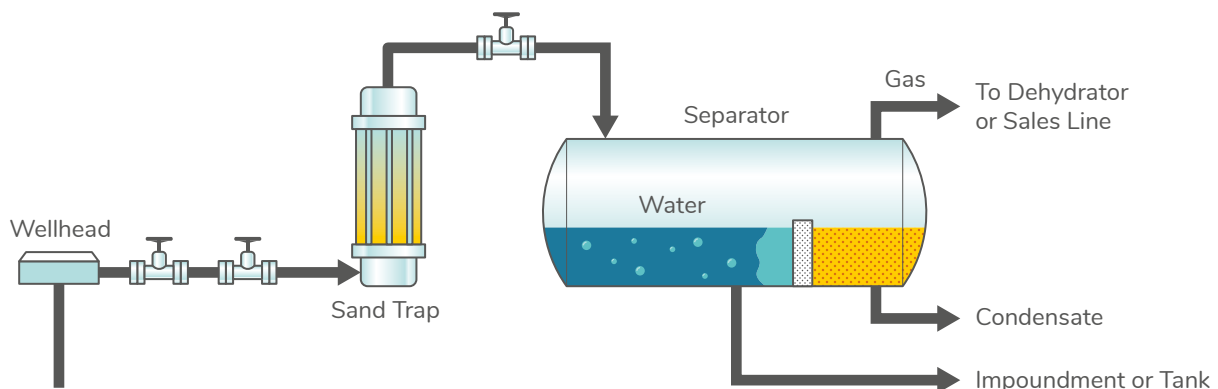

Source: Reference 7

Reduction in emissions and recovering costs

The economic benefits of reduced emissions from completion include reduced methane venting to the atmosphere. The EPA Gas Star guide on this subject⁷ shows a large financial return for these practices if the recovered gas is sold. If the gas is flared rather than recovered, methane emissions are still reduced.

Mitigation strategy 2c: Compress natural gas and transport it by road⁸

Gas which might otherwise be flared can be treated to remove water, sulfur and carbon dioxide, then compressed on-site to produce compressed natural gas (CNG). CNG must usually be treated further to make it a suitable quality for pipelines, so it can be transported by road to a gas-processing facility.

Transporting CNG to a gas-processing facility is usually economically viable for single-well, on-shore sites that are within 30 to 40km of the facility. Transporting CNG by road over longer distances may still be profitable for sites with multiple wells.

Reduction in emissions and recovering costs

Analyses⁸ have suggested that optimal gas volumes for this strategy are approximately 200,000 standard cubic feet per day (5,700 standard cubic meters per day) for single-well sites and 600,000 to 700,000 standard cubic feet per day (17,000 to 20,000 standard cubic meters per day) for multi-well sites. The most cost-effective solutions can achieve a 90% reduction in flaring accounting for a typical decline in production rates.

Higher percentages of reductions in flaring can be achieved by sacrificing some profitability.

Mitigation strategy 2d: Recover natural-gas liquids⁸

Recovering pipeline-quality natural gas from waste gas that might otherwise be flared will generally also involve recovering natural-gas liquids (NGL). NGL-recovery systems range from simple expansion-valve systems that only condense out the heaviest NGLs (pentane and heavier), to complex cryogenic technology using sub-zero temperatures. The choice of system depends on the NGL content of the gas and the end uses of the NGLs.

Pentane and heavier NGLs can be separated from waste gas using pressurized membrane systems and adsorption/absorption systems. These systems are generally suitable for large-scale systems. Refrigeration and valve-expansion separation of pentane and heavier NGLs are generally suitable for small-scale operations and are fairly inexpensive. For recovering lighter NGLs such as propane, heat exchange and mechanical refrigeration are generally economical approaches. For high-pressure systems, 'Joule-Thompson' units can be used, although they generally have higher initial costs than mechanical refrigeration. 'Cryogenic turbo-expansion' recovery is the most expensive option but can recover more gases.⁸

Reduction in emissions and recovering costs

Reported costs can be less than US\$0.07 per standard cubic meter (US\$2.00 per thousand standard cubic feet), based on gas flows of 10,000 standard cubic meters per day and on-shore locations within 80km of the gas-processing facility.⁸

Figure 5: Transporting CNG and NGLs to a gas-processing facility by road

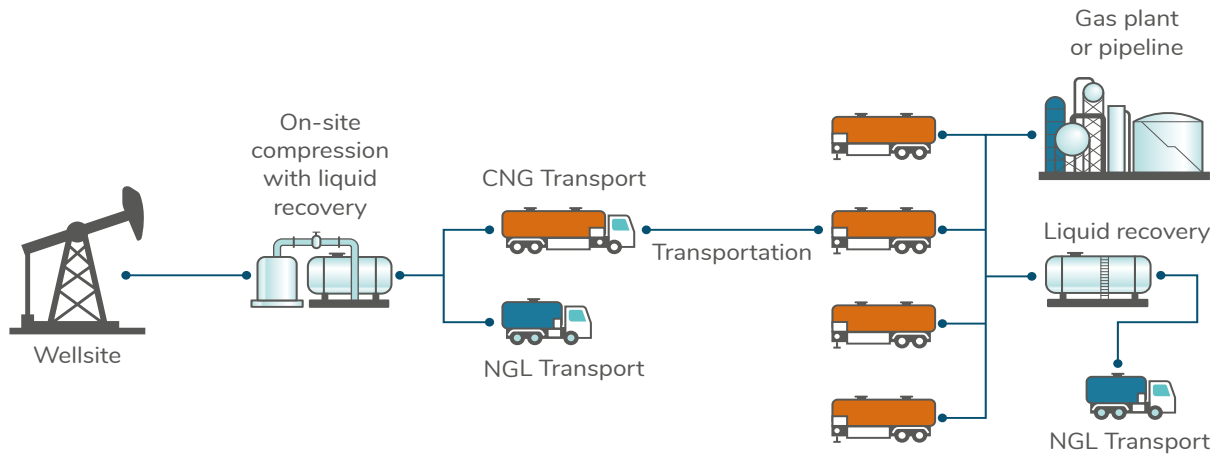

Source: Reference 7

Mitigation strategy 3: Store gases by injecting them into oil or gas reservoirs^{9,10}

Waste gas can be injected back into the reservoirs it was produced from, or other reservoirs, to increase oil production. In 2015, 17.5 trillion cubic feet of waste gas was reinjected worldwide,⁹ much more than the total volume of gas flared worldwide (5 trillion cubic feet or 145 billion cubic meters). Gas reinjection operations are unevenly distributed around the world (see figure 6 below), with most reinjection taking place in Algeria, Canada, Iran, Kazakhstan, Norway, the United States, the United Arab Emirates and Venezuela.⁹

The effectiveness of gas reinjection depends on the particular reservoir.

Figure 6: Global distribution of reinjected natural gas

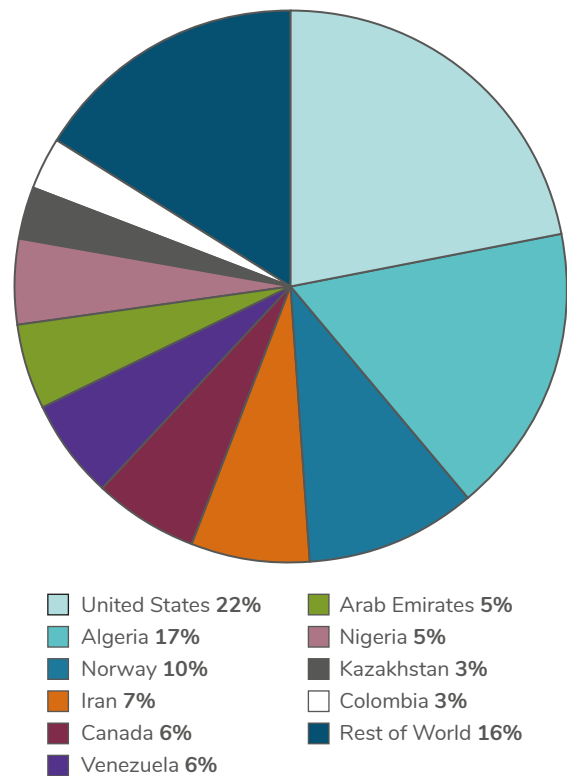

Source: Reference 9

Reduction in emissions and recovering costs

Based on the effectiveness of gas reinjection in the Bakken and Eagle Ford production regions in the United States, positive returns from increased oil production may result from gas reinjection.¹⁰

Mitigation strategy 4: Use flared gases to generate electricity⁸

Gas turbines and ‘reciprocating engines’ can convert gases into electricity. Typical sizes of operations range from 0.2 to 10MW, although there are microturbines of 30 to 250kW. The electricity can be used on-site to power other equipment (including controllers, pumps and air compressors) or can be sold to the grid.

Turbines generally require gases that contain few or no hydrocarbon liquids, and low levels of sulfur. For other gases, turbines may need to be combined with NGL recovery (see mitigation strategy 2d). Mixing raw gas with diesel fuel for use in reciprocating engines gets rid of the need for NGL recovery. Choosing which type and size of device to use is complex. During drilling and completion, the amount of power needed can range from 0.5MW to more than 15MW. During routine production, the amount of power typically needed is in the range of 0.1 to 0.15MW (for single-well sites) and 0.25 to 0.4MW (for multi-well sites). Because the power supply needs to be stable during production, and the flow of waste gas is often variable, some form of back-up power is generally needed.

Choosing the equipment you need is complex, not only because of variations in gas flow, but also because of the long-term decline in production, which may make one design better early on in a well’s life and a different design better in later stages.

For wells connected to the grid, selling the generated electricity to the grid is generally the best option.

Reduction in emissions and recovering costs

Burning waste gas in a turbine, rather than flaring it, may not reduce emissions. However, the electricity that is generated may reduce the need for other activities that cause emissions – on-site or off-site. Initial costs for this option have been reported⁸ in the range of US\$600,000 for a 0.5MW unit and

US\$1.2 million for a 2MW unit. A 2MW unit operating at full capacity generates electricity worth US\$350,000 to US\$1 million (with electricity priced at US\$0.02 per 0.06kWh), so payback times are typically more than a year, and larger units usually have shorter payback times. Payback times for using flared gas to replace diesel in engines may be more favorable, but this depends on engine types.⁸

Mitigation strategy 5a: Improve combustion in manned air- or steam-assisted flares¹¹⁻¹⁴

If flaring cannot be avoided, methane emissions can be minimized if the flaring is as efficient as possible. The design of the flare depends mainly on the volume of and variations in gas flow. Flares that burn large quantities of gas are often designed with air- or steam-assist devices that provide extra oxygen in the combustion zone (see figure 7 below). Increasing the flow of air or steam into the combustion zone of the flare can reduce the amount of smoke that is formed, but if too much air or steam is added, the efficiency of the flare can drop. Recent studies^{11,12} of large flares, of the design types that would be expected for large volumes of gas, showed that flare operation that achieved near complete (>98%) combustion, while minimizing smoke formation, required very careful control of assist rates.

Figure 7a: Steam-assisted flares (at the front, with smoking flame) and air-assisted flares (in the background) burning waste gases at high flow rates

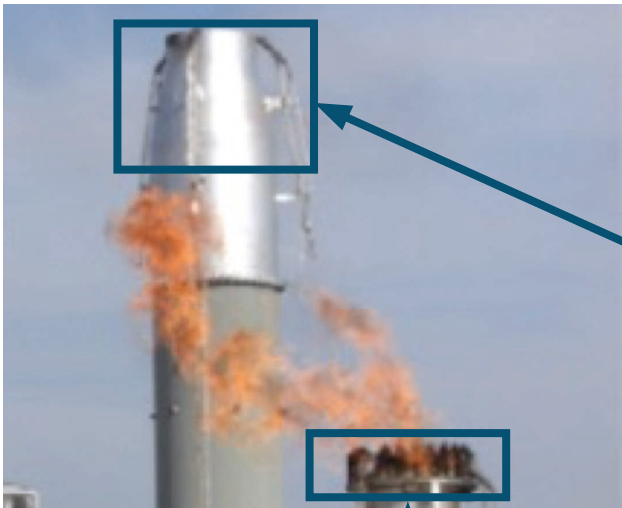

Figure 7b: An air-assisted flare with multiple wedge-shaped flow sections, alternating between air flow and gas flow



Figure 7c: Steam-injection nozzles ring the flare tip of a steam-assisted flare



Recent studies^{11,12} have found that it is difficult to minimize smoke and maintain the efficiency of combustion, especially if the waste gases have relatively low heating values and the flares are operating at a small fraction of their capacity. Maintaining assist rates that both minimize smoke and maximize combustion can often be achieved through skilled operation. Training on flare operation is available,¹³ but achieving desired flare combustion conditions may be difficult for flares with fixed assist rates, such as when fixed-speed blowers are used in air-assisted flares.¹⁴

Reduction in emissions and recovering costs

Skilled operation can be effective in improving the efficiency of combustion.¹³ However, some improvements in efficiency may require flares to be upgraded.

Source: University of Texas

Mitigation strategy 5b: Improve combustion in small flares at unmanned sites

Most small flares are at unmanned upstream sites.⁴ These flares are designed to handle small waste gas flows, abnormal operations, such as periods when a vapor-recovery unit (VRU) is over-pressured or out of service, or during completion. If any flare experiences flame out (where the flame goes out and combustion is not taking place), the flare acts as a vent stack and so is not efficient.

While many small flares prevent flame out by having a pilot light, or a spark ignitor with a flame monitor, a pilot light usually needs a separate, stable gas stream, such as supply from the gas line. A spark ignitor needs electrical or battery power.

Some jurisdictions, such as Canada and the US, now require a pilot light or spark ignitor for some or all wells and production sites.

Reduction in emissions and recovering costs

Pilot lights or spark ignitors can be added to many existing flares, or a flare can have them built in. The reduction of emissions from improved flare efficiency can be weighed against the cost of adding these devices.

Checklist

The following checklist allows you to assess your progress in reducing emissions from and through better use of flares.

Activity	Mark when completed	Percentage of sites included in the activity
✓ Keep an accurate inventory of the sources of vented gas		
✓ Keep an accurate inventory of the sources of flared gases, specifying the volumes of gas flared and the duration of flaring		
For each mitigation strategy, assess whether the volumes of gas flared and the duration of flaring will make the mitigation strategy viable. If the strategy is viable, track use of the mitigation strategy.		
✓ Prevent flaring (through multiple stages of separation in wells)		
✓ Recover remaining flared gases to sell as natural gas or natural-gas liquid		
a. Add vapor-recovery units on tanks		
b. Reduce flaring during well-testing and completion		
c. Compress natural gas and transport it by road		
d. Recover natural-gas liquids		
✓ Store gases through reinjection into gas or oil reservoirs		
✓ Find alternative uses for flared gases that cannot be recovered		
✓ Improve the efficiency of flares (if flaring is necessary)		
e. Improve efficiency of manned air- or steam-assisted flares		
f. Improve efficiency of small flares at unmanned sites		

Appendix

Links to more information about mitigation strategies

Mitigation Strategy	Description	Link to more information
1. Prevent the need for flaring	Add a second separator when designing wells	(5)
2. Recover flared gases and sell them as natural gas or natural-gas liquid	2a Add vapor-recovery units on tanks	(6)
	2b Reduce flaring during well-testing and completion	(7)
	2c Compress natural gas and transport it by road	(8)
	2d Recover natural-gas liquids	(8)
3. Store gases that would otherwise be flared	Store gases by injecting them into oil or gas reservoirs	(9,10)
4. Find alternative uses for flared gases	Use waste gases to generate electricity	(8)
5. Improve the efficiency of flaring	5a Improve combustion in manned steam- or air-assisted flares	(11-14)
	5b Improve combustion in small flares at unmanned sites	(13)

More information about flaring is reported in the World Bank Global Gas Flaring Reduction Partnership,¹ Johnson and Coderre,³ Allen, et al.,⁴; the US Environmental Protection Agency,¹⁵ the US National Academy of Science, Engineering and Medicine,¹⁶ and Porter, et al.¹⁷

References

- 1 World Bank, Global Gas Flaring Reduction Partnership; Estimates of Flaring using Satellite Data, available at <http://pubdocs.worldbank.org/en/603281560185748682/pdf/Gas-flaring-volumes-Top-30-countries-2014-2018.pdf> (2019)
- 2 International Energy Agency, 2019, Methane tracker: Reducing methane emissions from oil and gas operations, available at: www.iea.org/weo/methane.
- 3 MR Johnson and AR Coderre, 'Compositions and greenhouse gas emission factors of flared and vented gas in the Western Canadian Sedimentary Basin', Journal of the Air & Waste Management Association, 62:9, 992-1002, doi: 10.1080/10962247.2012.676954 (2012).
- 4 DT Allen, D Smith, VM Torres, and F Cardoso Saldaña, 'Carbon dioxide, methane and black carbon emissions from upstream oil and gas flaring in the United States', Current Opinion in Chemical Engineering, 13, 119-123 (2016).
- 5 Richard Roehner, Panja Palash and Deo Milind, 'Reducing gas flaring in oil production from shales', Energy & Fuels 30.9 (2016): 7524-7531
- 6 US Environmental Protection Agency (US EPA) https://www.epa.gov/sites/production/files/2016-06/documents/II_final_vap.pdf (2019).
- 7 US Environmental Protection Agency (US EPA) https://www.epa.gov/sites/production/files/2016-06/documents/reduced_emissions_completions.pdf, (2019)
- 8 Carbon Limits/Clean Air Task Force, 'Improving utilization of associated gas in US tight oil fields', Report and appendices available at www.catf.us/wp-content/uploads/2015/04/CATF_Pub_PuttingOuttheFire.pdf and www.catf.us/wp-content/uploads/2018/10/CATF_Pub_PuttingOuttheFire_Appendix.pdf (2015)
- 9 US Energy Information Administration (2017), Reinjected Gas, available at: www.eia.gov/beta/international/data/browser/#/?pa=002&c=rurvfvvtvnnv1urvfvfvvvvfvvou20evvvvvvvvvvvuvu&ct=0&tl_id=3002-A&vs=INTL.48-1-AFG-BCF.A&cy=2015&vo=0&v=H&end=2017
- 10 B. Todd Hoffman, Steve Sonnenberg, Hossein Kazemi and Qi Cui, 'The benefits of reinjecting instead of flaring produced gas in unconventional oil reservoirs', Available at www.onepetro.org/conference-paper/URTEC-1922257-MS (2014)
- 11 VM Torres, S Herndon, Z Kodesh, R Nettles and DT Allen, 'Industrial flare performance at low flow conditions: Part 1. Study Overview' Industrial & Engineering Chemistry Research, 51, 12559-12568, DOI: 10.1021/ie202674t (2012)
- 12 VM Torres, S Herndon and DT Allen, 'Industrial flare performance at low flow conditions: Part 2. Air and Steam assisted flares' Industrial & Engineering Chemistry Research, 51, 12569-12576, DOI: 10.1021/ie202675f (2012)
- 13 University of Texas, 'Supplemental Flare Operations Training' available at <https://sfot.ceer.utexas.edu/> (2019)

- 14 FM Al-Fadhli, VM Torres and DT Allen, 'Impacts of air assist flare blower configurations on flaring emissions' *Industrial & Engineering Chemistry Research*, 51, 12606-12610, DOI: 10.1021/ie3012209 (2012)
- 15 US Environmental Protection Agency (US EPA), *Inventory of US Greenhouse Gas Emissions and Sinks: 1990–2017* April 2019.
- 16 National Academies of Science, Engineering and Medicine (NASEM) 'Improving Characterization of Anthropogenic Methane Emissions in the United States' National Academy Press, Washington, DC (2018)
- 17 MD Porter, R Natili and A Strathman, 'Marcellus Shale Production Facility Emissions: Overcoming Challenges in the Liquids-Rich Area' Society of Petroleum Engineers, Eastern Regional Meeting (2016).



METHANE
GUIDING
PRINCIPLES